

# INDUSTRIAL ROTATOR CPR 5-01

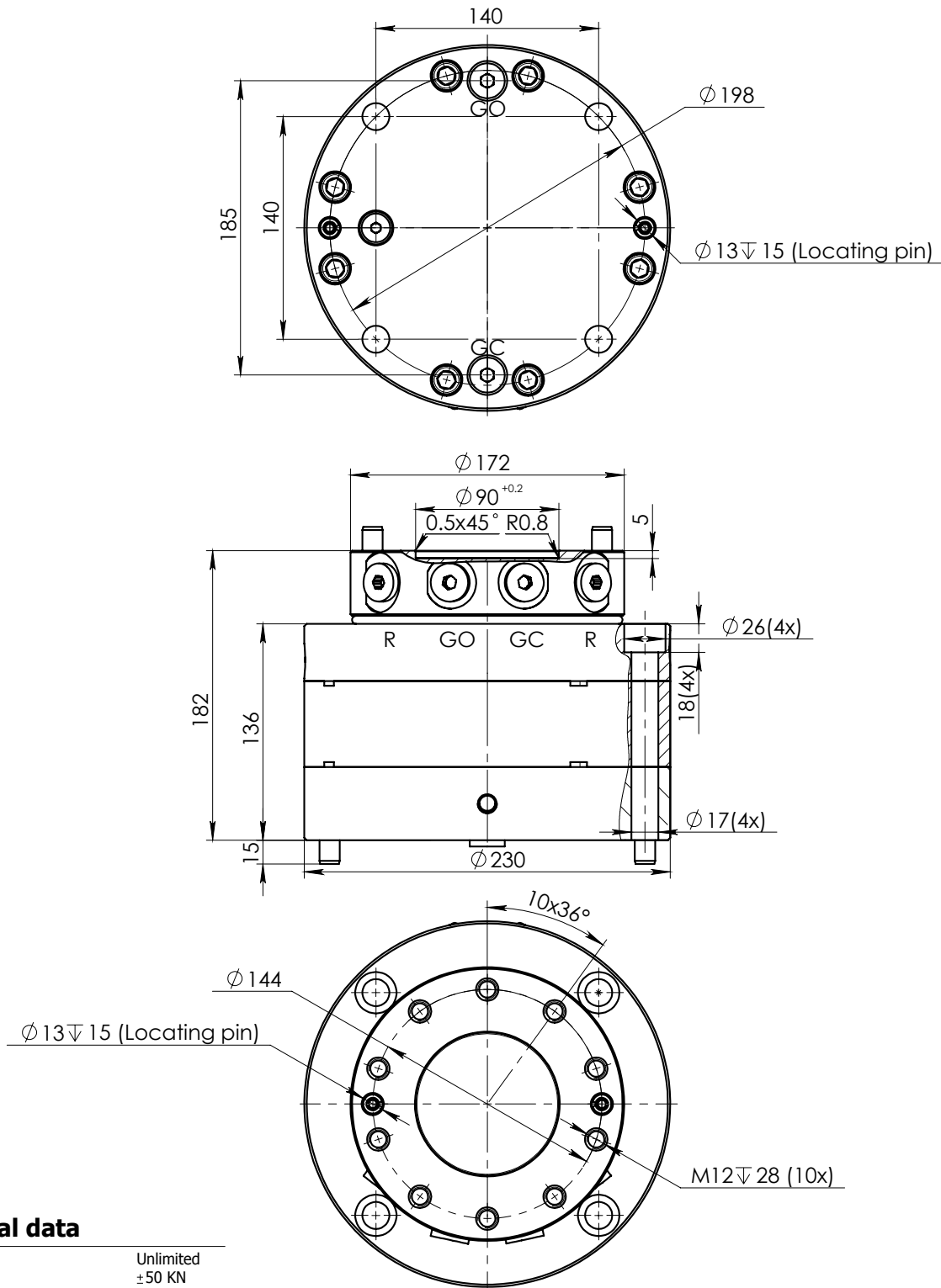

## Technical data

Rotation	Unlimited
Max axial load	±50 KN
Max radial load	36 KN
Torque at 25 Mpa	1350 Nm
Rated displacement	354 cm <sup>3</sup> /rev.
Rotation speed	max 30 rpm
Oil duct area for grapple	95 mm <sup>2</sup>
Weight	45 kg

Function	Max working pressure	Rec oilflow	Connection
<b>R</b> - rotation	25 MPa*	15 l/min	M 18x1.5
<b>GO</b> - grapple/tool open	35 MPa		Upper - M 18x1.5; Lower - G 3/8"
<b>GC</b> - grapple/tool close	35 MPa		Upper - M 18x1.5; Lower - G 3/8"

\* Relief valves fitted