

# INDUSTRIAL ROTATOR **CPR15-01**

(PATENTED)

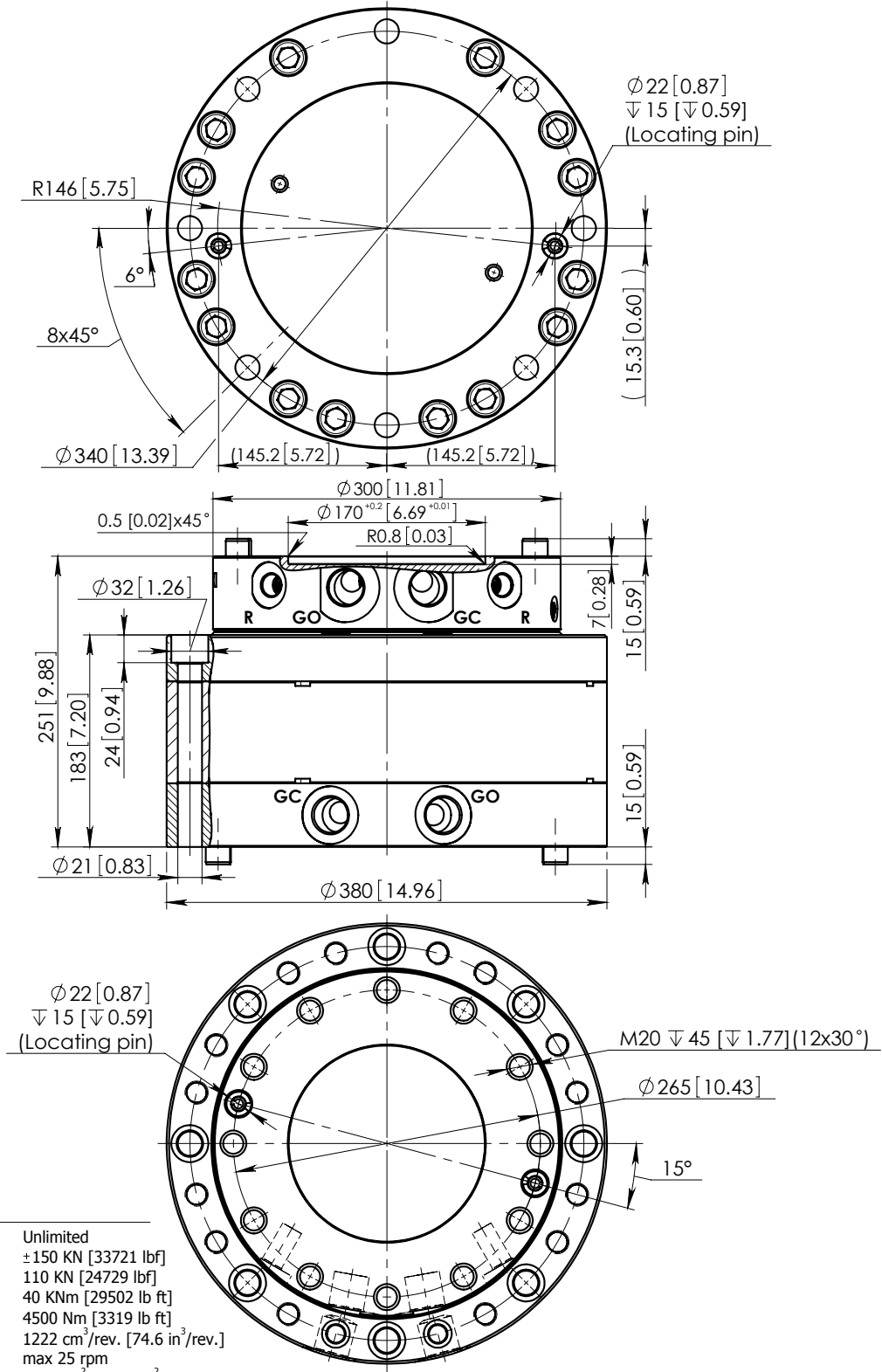

## Technical data

Rotation	Unlimited
Max axial load	± 150 KN [33721 lbf]
Max radial load	110 KN [24729 lbf]
Moment of deflection	40 KNm [29502 lb ft]
Torque at 25 Mpa	4500 Nm [3319 lb ft]
Rated displacement	1222 cm <sup>3</sup> /rev. [74.6 in <sup>3</sup> /rev.]
Rotation speed	max 25 rpm
Oil duct area for grapple	260 mm <sup>2</sup> [0.403 in <sup>2</sup> ]
Weight	178 kg [392 lb]

Function	Max working pressure	Rec oilflow	Connection
<b>R</b> - rotation	25 MPa [3625 psi] *	35 l/min [9.2 gal(US)/min]	G 1/2
<b>GO</b> - grapple/tool open	35 MPa [5076 psi]		G 1
<b>GC</b> - grapple/tool close	35 MPa [5076 psi]		G 1

\* Relief valves fitted