

# LINK BR 10

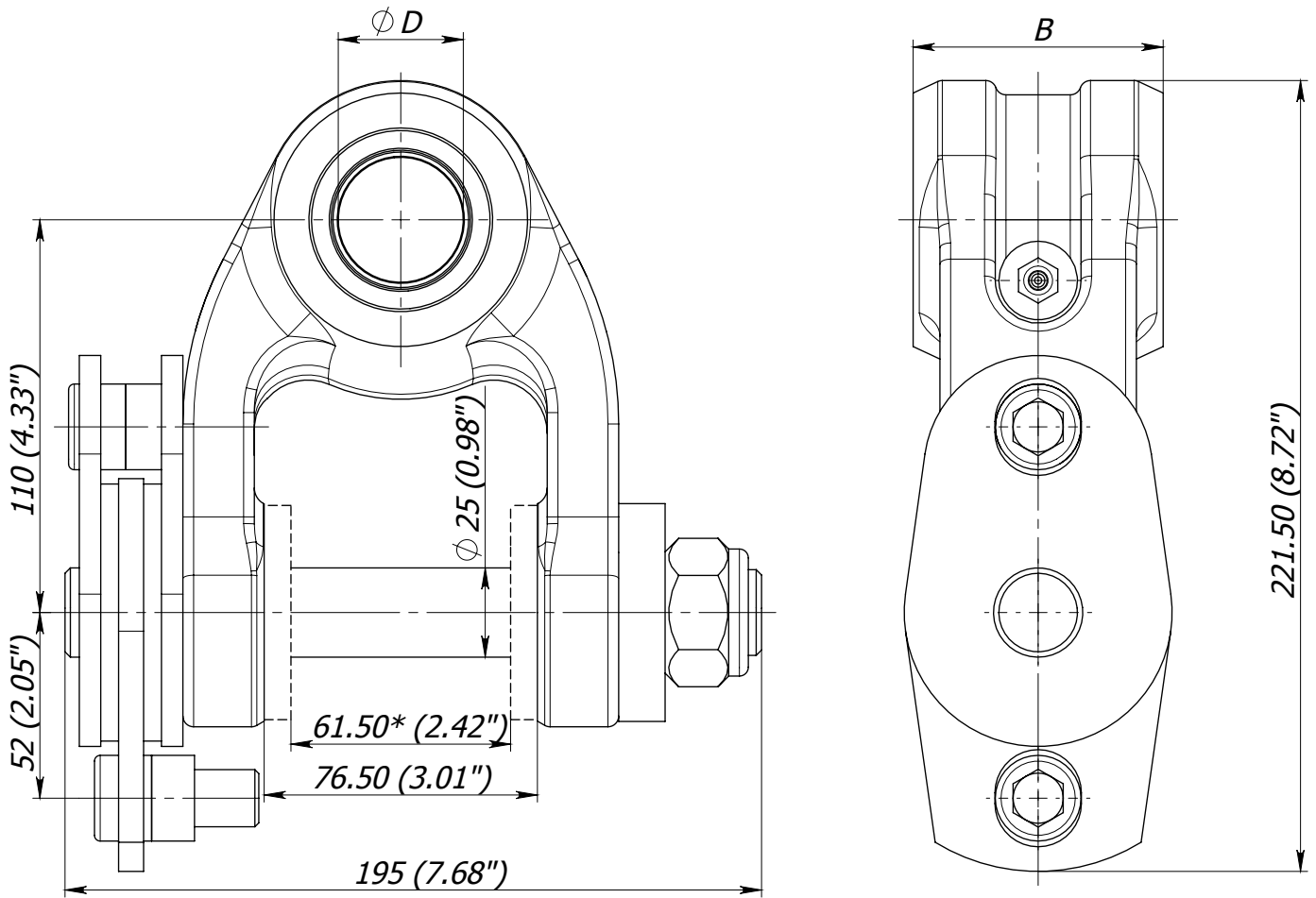

\* Only by request for rotator GR 30

Dimensions			
Crane nose pivot pin diameter $\varnothing D$ (mm)	Link width B (mm)		
	$80_{-0.3}^0$ (3.15")	$70_{-0.3}^0$ (2.76")	$60_{-0.3}^0$ (2.36")
45 (1.77")	BR 10/80/45	BR 10/70/45	
35 (1.38")	BR 10/80/35	BR 10/70/35	
30 (1.18")	BR 10/80/30	BR 10/70/30	BR 10/60/30
25 (0.98")	BR 10/80/25	BR 10/70/25	BR 10/60/25

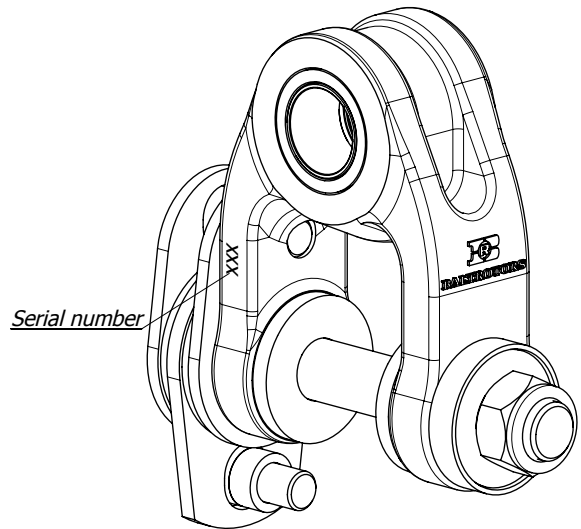

- Pin locking nut is tightened with a torque of 60 - 160 Nm (45 - 120 lb ft) dependent on desired brake power.
- Weight -  $6.5 \pm 1$  kg ( $14.55 \pm 2.20$  lb)
- Fill grease Starplex EP 2, through lubricating nipple (pos. 15), until it will appear to the external surfaces. Greasing must be repeated after every 8 working hours of the link.