

HARVESTER KIT **BMB32KS**

Our newest top-of-the-line PATENTED HARVESTER SWING DAMPER KIT

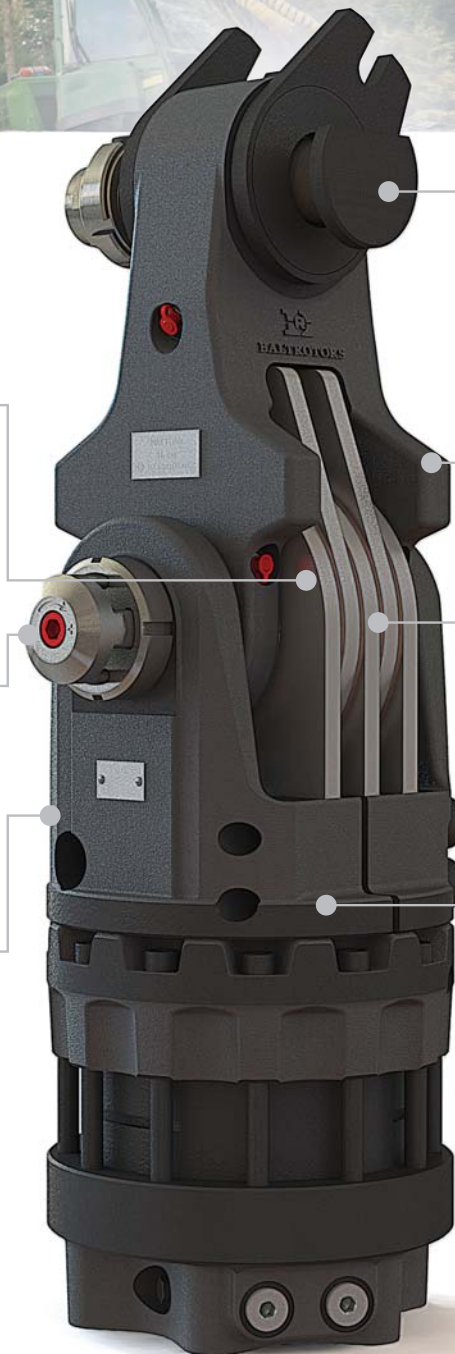

Reliable counter disks made with high strength and toughness steel

Braking torque can be set from 1200Nm to 1400Nm with easy one bolt adjustment

Coming in Summer 2013: HR12-02 and HR16-02 harvester rotators with housing from top or bottom of the rotator

Upper conical brake compatible with most crane booms

Thick durable steel body

Breaks are easy to maintain and replace – no full dismounting needed

For Baltrotors HR rotators:
HR12-01
HR12-02
HR16-01
HR16-02

BMB32KS

Friction discs with specially designed self-cleaning grooves

Adjustable tensioner with high precision compression springs pressing the friction and counter disks near the braking area

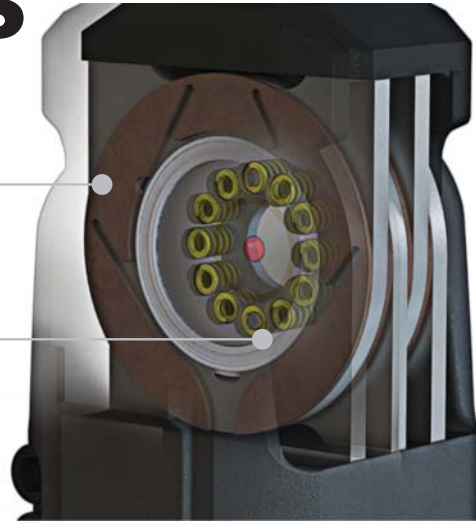

BMB32KS

Max load 160kN

Adjustable braking torque of the disc brake 1200Nm to 1400Nm

Weight 38kg

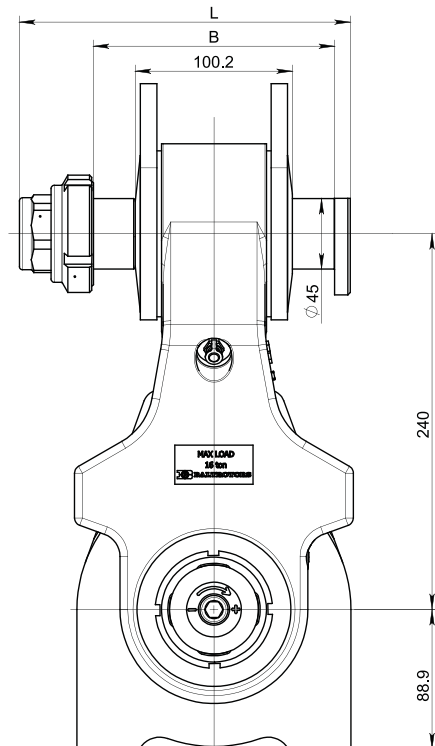
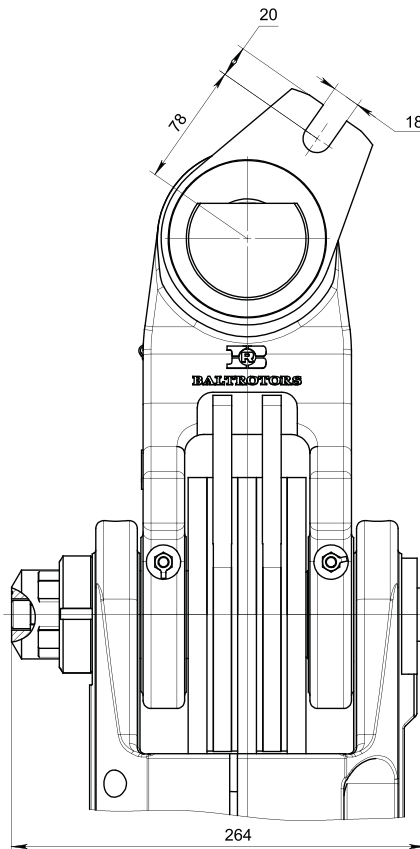

Link	B(mm)	L(mm)
BMB32KS-240	240	310
BMB32KS-230	230	300
BMB32KS-200	200	270
BMB32KS-190	190	260
BMB32KS-180	180	250
BMB32KS-170	170	240
BMB32KS-160	160	230
BMB32KS-150	150	220
BMB32KS-140	140	210
BMB32KS-130	130	200